

**100%** Money Back  
**Guarantee**

**Vendor:**Juniper

**Exam Code:**JN0-648

**Exam Name:**Enterprise Routing and Switching,  
Professional (JNCIP-ENT)

**Version:**Demo

## QUESTION 1

Click the Exhibit button.

```
user@router-> show log ospf-trace.log
Oct 8 16:20:26.812781 OSPF packet ignored: no matching interface from
192.168.0.2, IFL 75
Oct 8 16:20:26.812804 Received OSPF packet of type and wire_length 1, 60
Oct 8 16:20:26.812807 OSPF rcvd Hello 192.168.0.2 -> 224.0.0.5 (ge-0/0/2.0
IFL 73 area 0.0.0.1)
Oct 8 16:20:26.812809 Version 2, length 48, ID 172.29.0.5, area 0.0.0.1
Oct 8 16:20:26.812810 checksum 0x0, authtype 0
Oct 8 16:20:26.812812 mask 255.255.255.252, hello_ivl 10, opts 0x18, prio
128
Oct 8 16:20:26.812814 dead_ivl 40, DR 192.168.0.2, BDR 0.0.0.0
Oct 8 16:20:26.812816 OSPF restart signaling: Received hello with LLS data
from nbr ip=192.168.0.2 id=172.29.0.5
Oct 8 16:20:26.812818 OSPF packet ignored: configuration mismatch from
192.168.0.2 on intf ge-0/0/2.0 area 0.0.0.1
Oct 8 16:20:26.812831 OSPF packet ignored: no matching interface from
192.168.0.2, IFL 72
Oct 8 16:20:30.520194 OSPF periodic xmit from 192.168.0.1 to 224.0.0.5 (IFL
73 area 0.0.0.1)
Oct 8 16:20:30.520546 OSPF packet ignored: no matching interface from
192.168.0.1, IFL 75
Oct 8 16:20:30.520561 OSPF packet ignored: no matching interface from
192.168.0.1, IFL 72
Oct 8 16:20:36.114424 OSPF packet ignored: no matching interface from
192.168.0.2, IFL 75
Oct 8 16:20:36.114447 Received OSPF packet of type and wire_length 1, 60
Oct 8 16:20:36.114449 OSPF rcvd Hello 192.168.0.2 -> 224.0.0.5 (ge-0/0/2.0
IFL 73 area 0.0.0.1)
Oct 8 16:20:36.114451 Version 2, length 48, ID 172.29.0.5, area 0.0.0.1
Oct 8 16:20:36.114452 checksum 0x0, authtype 0
Oct 8 16:20:36.114454 mask 255.255.255.252, hello_ivl 10, opts 0x18, prio
128
Oct 8 16:20:36.114455 dead_ivl 40, DR 192.168.0.2, BDR 0.0.0.0
Oct 0 16:20:36.114450 OSPF restart signaling: Received hello with LLS data
from nbr ip=192.168.0.2 id=172.29.0.5.
Oct 8 16:20:36.114460 OSPF packet ignored: configuration mismatch from
192.168.0.2 on intf ge-0/0/2.0 area 0.0.0.1
```

A router is attempting to form an OSPF neighborhood with another router. However, the OSPF neighborhood fails to establish completely.

Referring to the exhibit, what is the problem?

- A. There is an interface type mismatch.
- B. There is an interface subnet mask mismatch.

C. There is an OSPF area mismatch.

D. There is an interface MTU mismatch.

Correct Answer: A

---

## **QUESTION 2**

Click the Exhibit button.

```

[edit]
uer@router# show policy-options
prefix-list known-ok-sites {
    10.10.0.0/16;
    12.233.0.0/18;
    172.16.0.0/24;
    192.168.12.0/24;
}

prefix-list known-dir-bcast-sites {
    10.2.0.0/16;
    12.233.45.0/24;
    172.16.0.3/32;
    192.168.1.0/24;
}

policy-statement prefix-list-policy {
    term 1 {
        from {
            prefix-list known-ok-sites;
        }
        then accept;
    }
    term 2 {
        from {
            prefix-list known-dir-bcast-sites;
        }
        then reject;
    }
    term 3 {
        from {
            route-filter 12.233.45.5/32 exact;
        }
        then next policy;
    }
}

```

The policy shown in the exhibit is applied as an export policy to your BGP neighborhood. Which action will be taken for route 12.233.45.5?

- A. It will be rejected by term 2.
- B. It will be accepted by term 1.

- C. It will be accepted by the default policy.
- D. It will be evaluated by the next policy.

Correct Answer: B

### QUESTION 3

Click the Exhibit button.

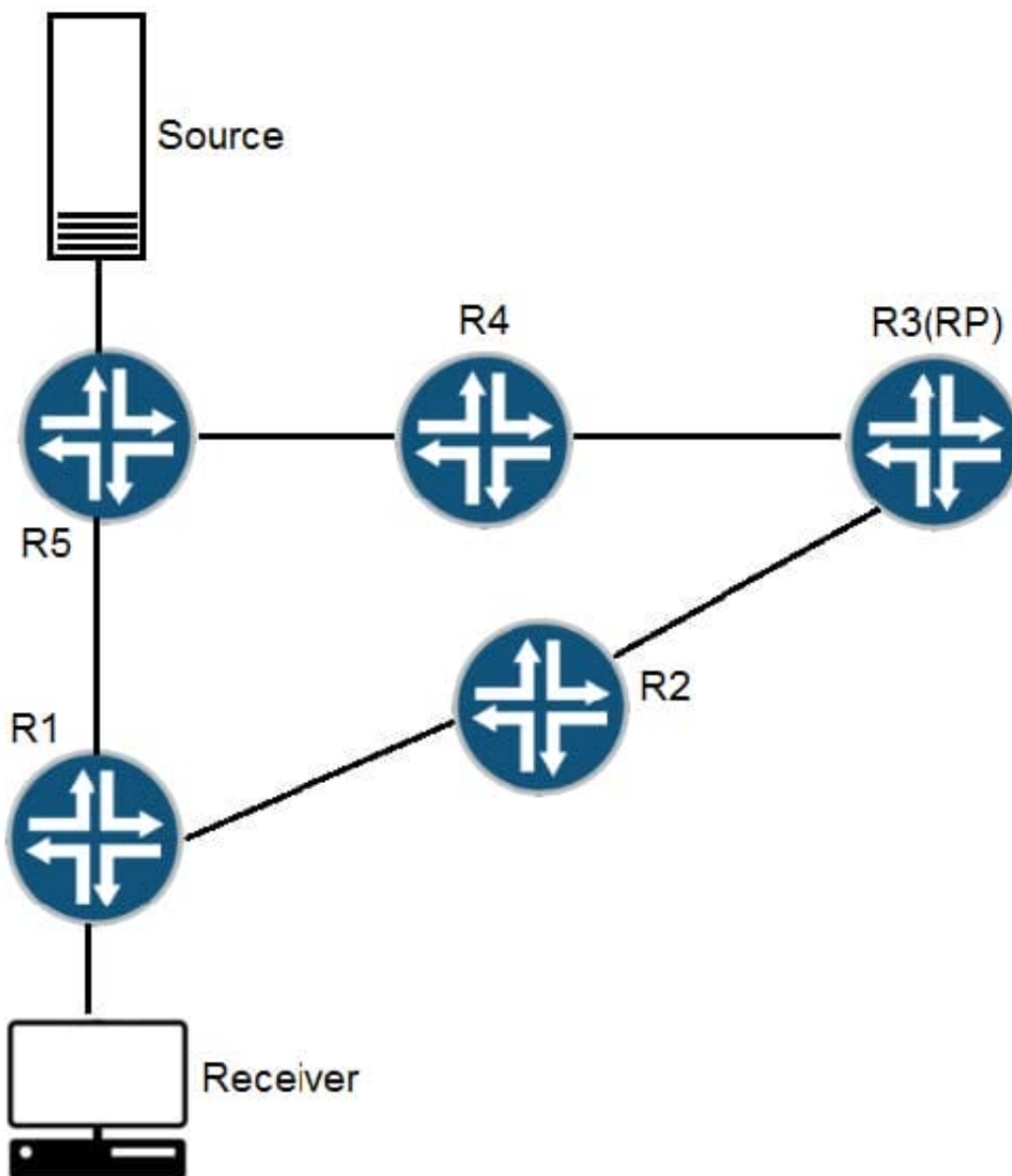

Referring to the exhibit, a PIM-SM network is set up to enable communication between multicast devices. Which statement is true in this scenario?

- A. After the formation of the shortest-path tree, a prune message is sent from R1 to R5.
- B. After the formation of the shortest-path tree, a prune message is sent from R1 to R2.
- C. After the formation of the shortest-path tree, a join message is sent from R5 to R1.
- D. After the formation of the shortest-path tree, a join message is sent from R1 to R5.

Correct Answer: B

---

#### QUESTION 4

Which three types of ports are used for Junos Fusion Enterprise? (Choose three.)

- A. extended port
- B. authenticated port
- C. cascade port
- D. uplink port
- E. designated port

Correct Answer: ACD

---

#### QUESTION 5

You have configured CoS on a Junos device. A packet is classified as best effort by a behavior aggregate (BA) classifier, and as expedited forwarding by a multifield (MF) classifier.

Which statement is true in this scenario?

- A. The packet will be placed in a queue associated with the BA classifier.
- B. The packet will be placed into the queue which is least congested.
- C. The packet will be placed into the queue that has the most bandwidth assigned to it.
- D. The packet will be placed in a queue associated with the MF classifier.

Correct Answer: A

---

#### QUESTION 6

You have an MX960 configured as a Fusion aggregation device (AD) and two QFX5100 switches as satellite devices (SD). You have configured local-switching for each SD. A packet with an unknown MAC address is received on one of the SD extended ports.

Which statement is correct in this scenario?

- A. The packet is dropped and a reject message is sent out to the port where it was received.
- B. The packet is silently discarded and a reject message is sent to the AD.
- C. The packet is flooded out of all the ports on the SD except the one where it was received.
- D. The packet is sent to the AD to be processed and forwarded.

Correct Answer: D

---

#### **QUESTION 7**

Which two statements are correct about a functional ESI LAG interface? (Choose two.)

- A. The LACP system ID must be the same.
- B. The ESI values must be the same.
- C. The LACP system ID must be different.
- D. The ESI values must be different.

Correct Answer: AB

---

#### **QUESTION 8**

Click the Exhibit button.

```

(master:0)
user@R3> show route

inet.0: 8 destinations, 8 routes (7 active, 0 holddown, 1 hidden)
+ = Active Route, - = Last Active, * = Both

...
10.1.3.0/24      *[Direct/0] 00:13:55
                 > via ge-0/0/6.300
10.1.3.2/32      *[Local/0] 00:13:55
                 Local via ge-0/0/6.300
10.31.0.0/24     *[BGP/170] 00:00:07, localpref 100
                 AS path: 65414 I, validation-state: unverified
                 > to 10.1.3.1 via ge-0/0/6.300
10.210.14.224/27 *[Direct/0] 19w0d 01:47:22
                 > via me0.0
10.210.14.226/32 *[Local/0] 22w4d 17:39:04
                 Local via me0.0

(master:0)
user@R3> show route hidden

inet.0: 8 destinations, 8 routes (7 active, 0 holddown, 1 hidden)
+ = Active Route, - = Last Active, * = Both

10.30.0.0/24     [BGP/170] 00:00:10, localpref 100, from 10.1.3.1
                 AS path: 65414 I
                 Unusable

```

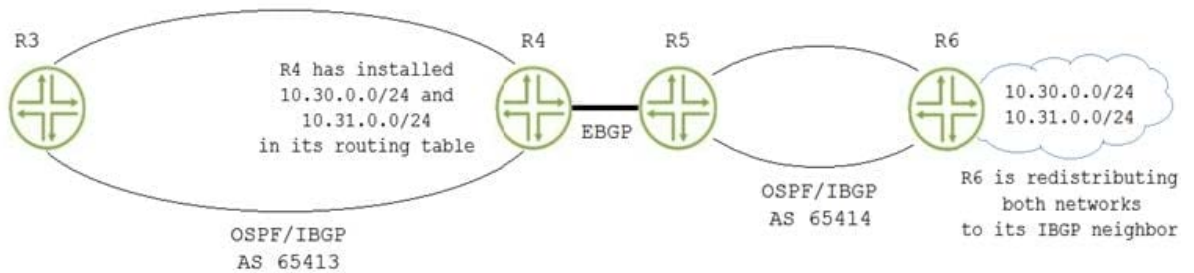

You are troubleshooting a route problem in the topology shown in the exhibit. The 10.30.0.0/24 route is not reachable from the R3 router.

What would cause this problem?

- A. R3 does not have an established BGP session with R4.
- B. R3 does not have a route to the BGP next hop of 10.30.0.0/24.
- C. R4 is not advertising the 10.30.0.0/24 route to R3.
- D. R3 does not have an OSPF route for 10.30.0.0/24.

Correct Answer: B

## QUESTION 9

Which two statements are true regarding bidirectional PIM? (Choose two.)



- A. Forwarding paths can be suboptimal.
- B. Devices only store group specific entries.
- C. It uses multicast tunneling to forward traffic.
- D. It eliminates the need for an RP.

Correct Answer: AB

### QUESTION 10

Click the Exhibit button.

	AS-Path	MED	Local Preference	Origin
ISP-A	100 200 1	50	150	?
ISP-B	3000 1500	50	100	E
ISP-C	5000 4000	50	100	I
ISP-D	1000 7000	50	100	I

You receive the same 100.200.0/16 route from all four ISPs to which you are connected. Referring to the exhibit, which ISP's route will be selected as active?

- A. ISP-C
- B. ISP-D
- C. ISP-A
- D. ISP-B

Correct Answer: C

### QUESTION 11

Your company has expanded into office space across the street. The new office space has a single Ethernet connection connected to an unmanaged switch. You must sort traffic based on the IP address into different VLANs once the traffic arrives on your EX Series switches.

Which mechanism would you use to accomplish this task?

- A. MVRP
- B. filter-based VLANs

C. Q-in-Q tunneling

D. dynamic VLANs

Correct Answer: B

---

## QUESTION 12

Click the Exhibit button.

```
{master:0} [edit]
user@router# show firewall three-color-policer main-policer
action {
    loss-priority high then discard;
}
single-rate{
    color-aware;
    committed-information-rate 40m;
    committed-burst-size 100k;
    excess-burst-size 200k;
}
```

You have configured and applied the policer shown in the exhibit to your Junos device. Which statement is true in this scenario?

A. Traffic exceeding the committed-burst size will be marked with a loss priority of high.

B. Traffic exceeding the excess-burst size will be discarded.

C. Traffic exceeding the committed-information-rate will be rate limited.

D. Traffic exceeding the committed-burst size will be discarded.

Correct Answer: A